

HOWDEN WATER TECHNOLOGIES

HIGH EFFICIENCY CENTRIFUGAL TURBO BLOWERS AND SYSTEMS
FOR THE GLOBAL WASTE WATER TREATMENT INDUSTRY



A NEW BENCHMARK FOR ENERGY EFFICIENCY & CONTROL

PART OF HOWDEN PROCESS COMPRESSORS, THE CENTRE OF EXCELLENCE FOR TURBO BLOWER & COMPRESSOR SYSTEMS, HOWDEN WATER TECHNOLOGIES SERVES AS OUR SPECIALIST BUSINESS CENTRE SUPPLYING HIGH EFFICIENCY TURBO BLOWER SYSTEMS AND OUR BIOACTIVE RESPONSE SYSTEM (BARS) TO THE GLOBAL WASTE WATER INDUSTRY.

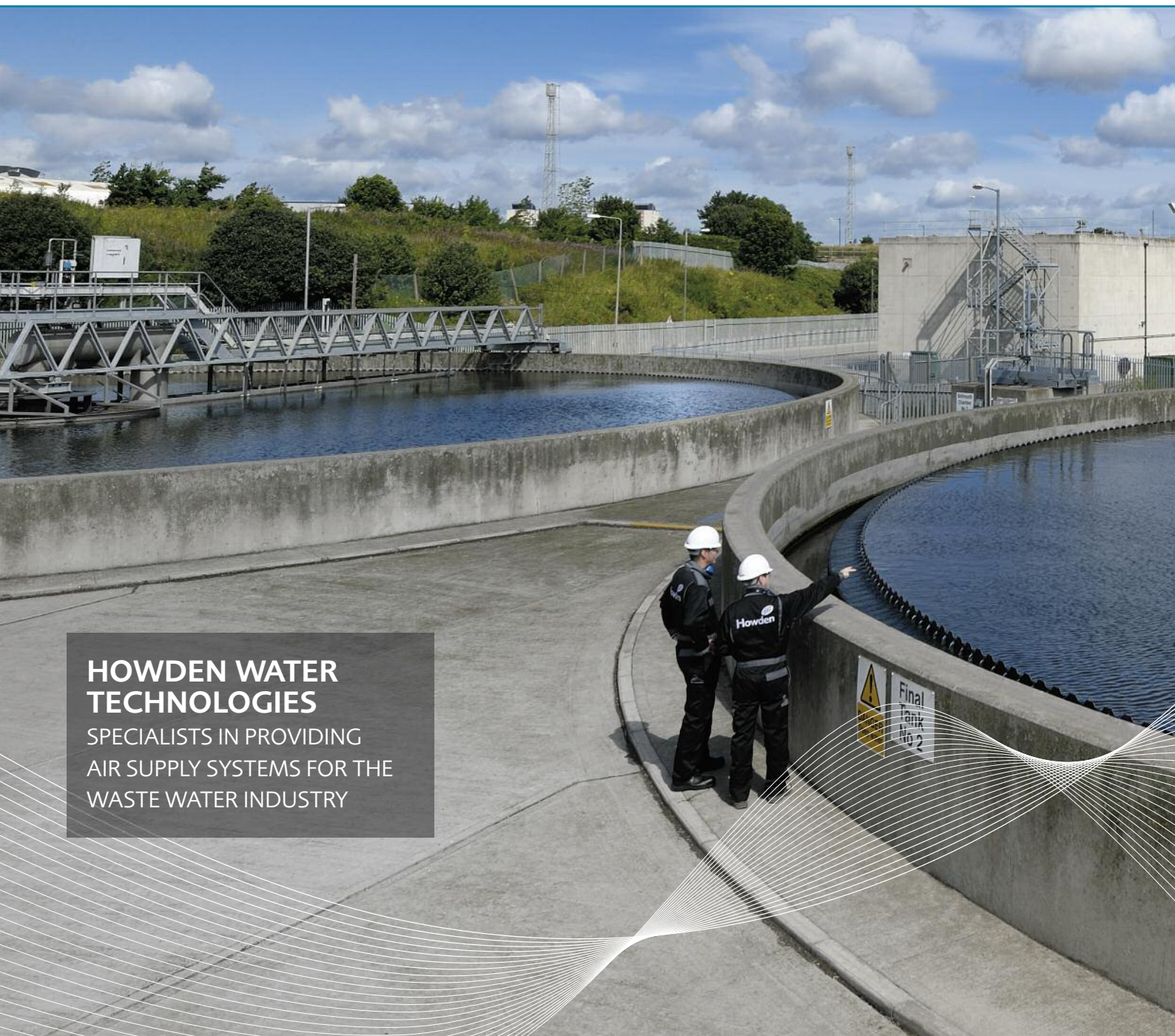

HOWDEN WATER TECHNOLOGIES

SPECIALISTS IN PROVIDING AIR SUPPLY SYSTEMS FOR THE WASTE WATER INDUSTRY

WORLD CLASS APPLICATION ENGINEERING

Howden Water Technologies is Howden's specialist business centre serving the global municipal waste water market. As part of Howden Process Compressors, and Howden's Compressor Division, we supply a range of high efficiency turbo blowers and associated equipment for the waste water industry. Furthermore, through our BioActive Response System (BARS) we offer a highly-efficient aeration control system that optimises the operations of our turbo blowers.

GLOBAL REACH

Working on every continent, and with companies in 17 countries, Howden has made an enormous contribution to environmental improvements within the Water, Oil & Gas, Power, Industrial, and Mining

industries. With over 1,200 installations worldwide, Howden turbo blowers are the proven, reliable choice for optimal performance.

EXPERTISE BUILT ON EXPERIENCE

Howden has been supplying blowers to waste water treatment plants for over fifty years. By combining our high efficiency turbo blowers with our sophisticated downstream control systems (BARS) developed especially for the water treatment market, we can offer the most advanced and efficient aeration systems available.

MINIMISING ENERGY CONSUMPTION

The need to minimise energy consumption, whether for cost or environmental reasons, has become a factor of enormous significance, and the aeration

system is responsible for by far the largest proportion of the energy consumption in any aerobic waste water treatment plant. Howden turbo blowers can provide the lowest footprint and highest flow. The exceptional performance is based on a third generation high performance impeller that enables the blower to operate 8–10% below the surge line during normal running, giving an extremely high margin when compared to other blower products available today. The whole system is governed by a modern control system incorporating an easy-to-use human-machine interface. Over the lifetime cost of the equipment, Howden Water Technologies offers the highest cost savings through a combination of energy efficiency and the reliability offered by our 'built to last' philosophy.



THE POWER BEHIND THE PROCESS

OVER THE LIFE OF THE PLANT, HOWDEN TURBO BLOWERS ARE BY FAR THE MOST COST EFFECTIVE TECHNOLOGY AVAILABLE. THEIR CAPITAL COST WILL QUICKLY BE OFFSET BY LOWER ENERGY EXPENDITURE, TYPICALLY AS EARLY AS THE FIRST 12 TO 36 MONTHS OF OPERATION, LEAVING DECADES FOR THE SAVINGS TO GROW.

Howden turbo blower technology has an installed base numbering over one thousand two hundred units worldwide. These machines typically run for decades without any intervention except minimal planned maintenance. Their robust success is a testimony to the quality of their engineering, and their track record is a provable fact.

Howden Water Technologies offers a choice of 15 frame sizes with a capacity flow of up to 130,000 M³/Hr (80,000 CFM), covering the most extensive duty range on the market. With the widest volume and pressure range available, Howden Water technologies can supply a product to meet any demand our clients have – and with achievable efficiency levels exceeding 87%, Howden is the natural choice for water treatment plants.

Our turbo blowers are designed to provide plant operators with efficiency across the actual operating range. Exceptional turndown capability is built in as

standard to ensure that when plants are operating at low load, the efficiency of the aeration system is unaffected. Howden Water Technologies products will maintain effectiveness through the full flow range, including the key 60-80% window and dropping to as low as 40% capacity when required.

Every unit we supply is fitted with dual vane blower regulating systems, comprising both variable inlet guide vanes and a variable vane diffuser system. The inlet guide vanes create a pre-rotational air swirl before the air reaches the impellers, adding significantly to the efficiency of the equipment at turn-down duty, and the variable vane diffuser is designed to control the pressure build-up at the impeller discharge while also regulating the blower capacity.

Prior to shipment each unit is fully factory tested. We offer the choice of testing to ASME PTC10-1997 or ISO 5389 specification, and supply the performance certificate, at the customer's request.

HOWDEN 'SG' & HYDRA CENTRIFUGAL TURBO BLOWER RANGE

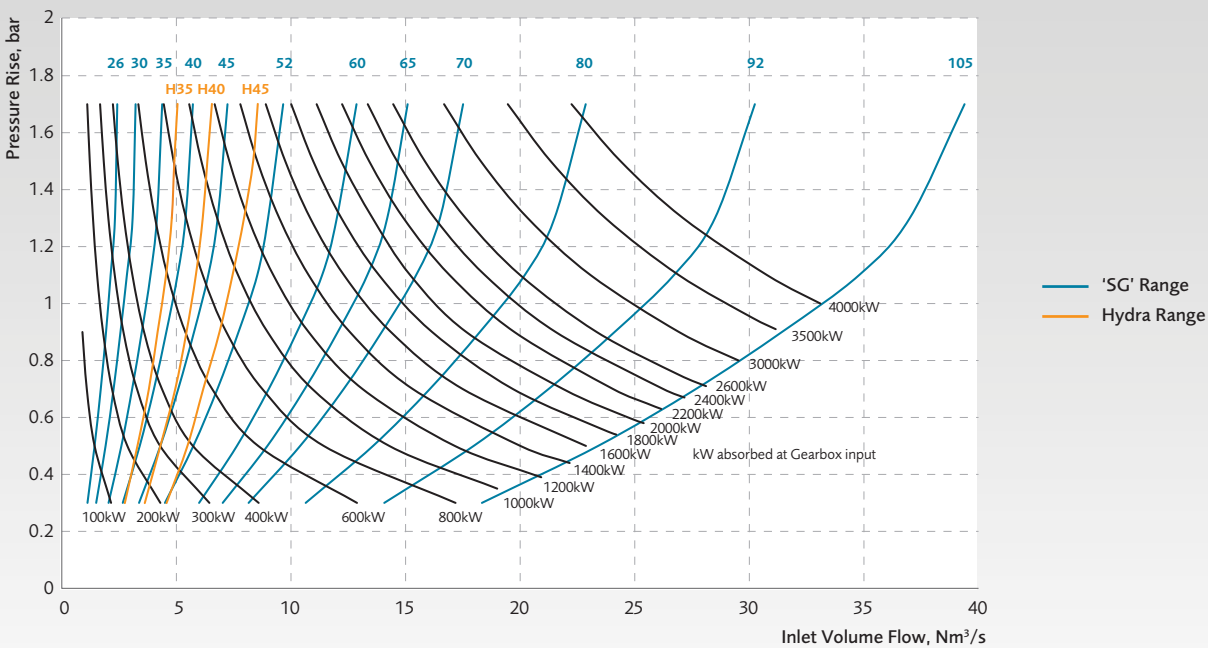

SG26



SG30



SG35 & SGH35



SG40 & SGH40



SG45 & SGH45

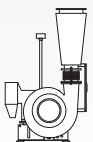

SG52

TURBO BLOWER SYSTEM WITH ANCILLARY EQUIPMENT

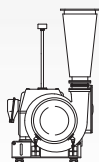
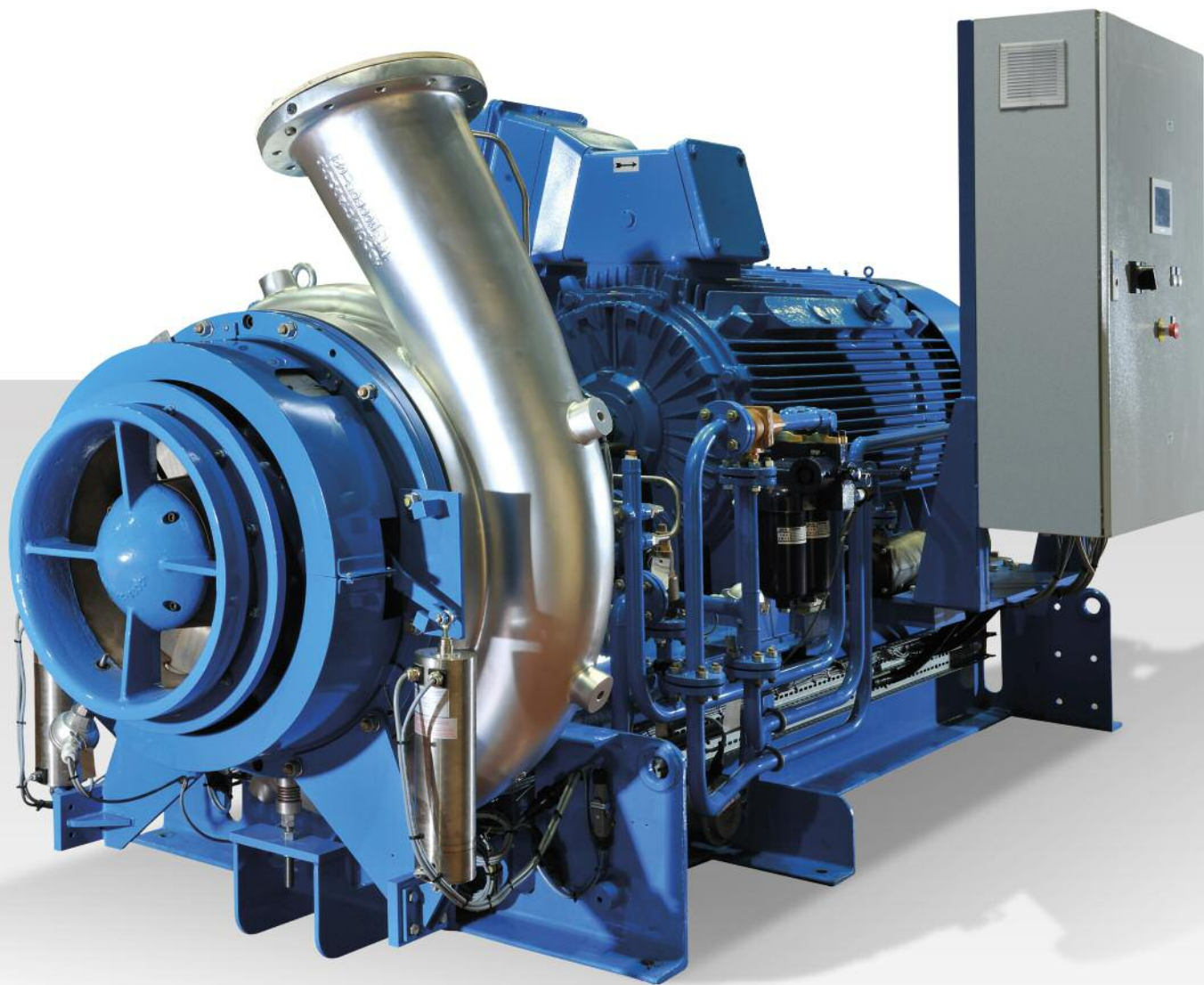
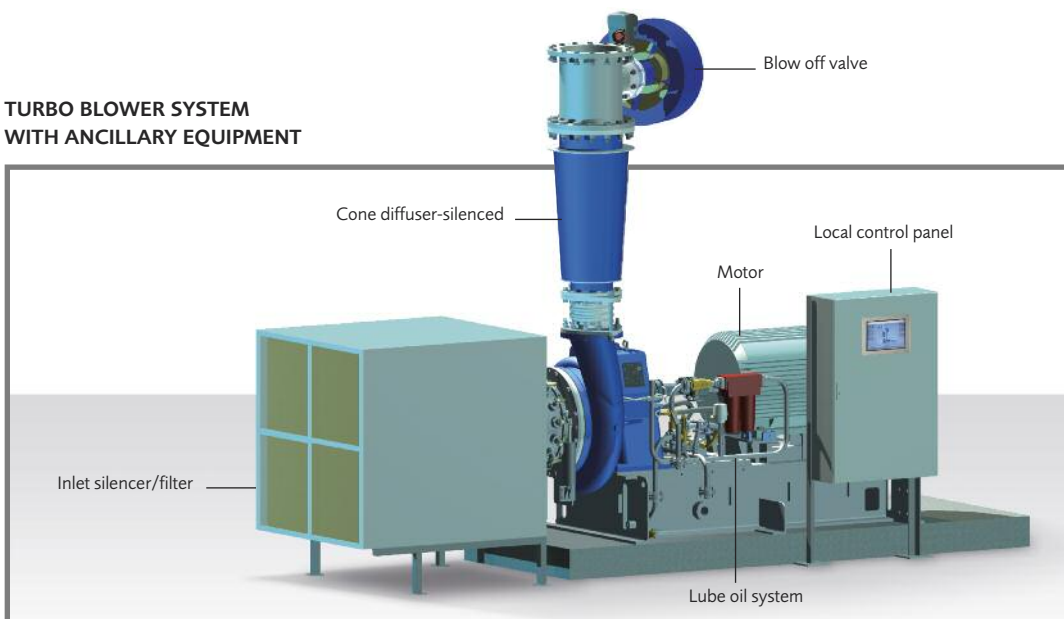

SG60



SG65



SG70

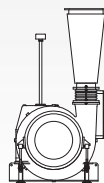

SG80

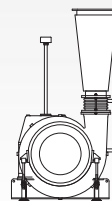

SG92

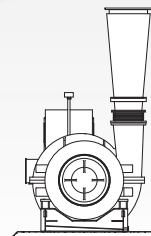

SG105

RESPONSIVE INTEGRATED TECHNOLOGY

DESIGNING AND SPECIFYING A MODERN, ENERGY-EFFICIENT AERATION SYSTEM IS A COMPLEX TASK, DEMANDING DETAILED KNOWLEDGE OF THE COMPRESSION PROCESS AS WELL AS THE OPERATION AND CONTROL OF THE AIR DISTRIBUTION SYSTEM, AND A THOROUGH UNDERSTANDING OF THE ACTIVE SLUDGE WATER TREATMENT PROCESS.

PROVEN EFFICIENCY

Howden turbo blowers high efficiency systems have been thoroughly researched and tested to provide flexibility and control even when plant conditions require greatly reduced capacity. Our figures relate directly to the working efficiency of our turbo blowers once installed and running. They will be reflected in genuine energy savings.

All blowers, whether they use rotary lobe blower (positive displacement), multi stage centrifugal blower or turbo blower technology, are designed to work at peak efficiency when they are running at full capacity.

When the capacity drops to normal operating levels, however, the efficiency may fall away dramatically. Of the three technologies turbo blowers are the most efficient, approaching 87% efficiency at full capacity.

Howden turbo blowers, with their inlet guide vanes, variable vane diffusers and enhanced impeller design, have a clearly measurable advantage in maintaining excellent performance in the full operating range of 45-100% capacity. Howden turbo blowers excel where plant conditions dictate that blowers operate away from the design point, giving significant operational benefits.

PERFORMANCE CURVES

TURNDOWN AND RISE TO SURGE

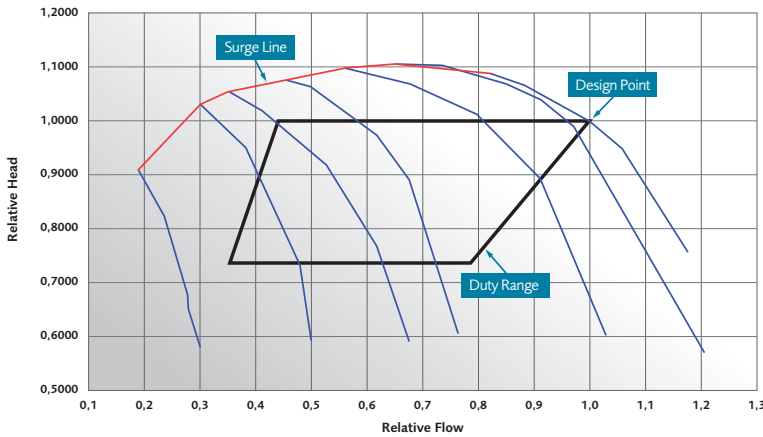

VARIABLE VANE DIFFUSER

The Howden variable vane diffuser system is designed to be easy to access for service and maintenance to minimise down time.



IMPELLER

Howden's third generation impeller is a core 3D high performance impeller designed for maximum efficiency and a severe downturn capability. By maintaining performance at operating levels far from the surge line, it provides maximum operating stability. The S-shaped impeller has strong backward leaning blades and every second blade in the inducer is cut back to avoid blockages in the inducer section. This unique aerodynamic design offers our clients maximum efficiency across the full duty range. It also gives a head stability margin of 8-10% from maximum duty head to surge, thus lowering vulnerability to ambient changes and reducing down time.





**HOWDEN WATER
TECHNOLOGIES**
IS AN INVALUABLE SOURCE
OF APPLICATION EXPERTISE
AS WELL AS A SUPPLIER OF
COMPLETE, INTEGRATED
AIR SUPPLY SYSTEMS

PREDICTING REAL PERFORMANCE

The understanding that no two plants will ever operate in exactly the same conditions, and our certainty that we can deliver efficiencies and energy savings, led us to the development of our unique modelling software.

This compares different types of air supply technology within the precise parameters of the customer's own plant. Alongside the volume and pressure of air required, there are many other factors which affect operation. We factor in the time the plant runs at full, high average, low average and minimum capacity,

and add ambient conditions like relative humidity and temperature, and variables like energy availability and cost, using figures supplied by the customer.

Allowance can be made for energy price rises and maintenance over a 20-year operating period. The software is designed to precisely mirror genuine working duties and ambient conditions, and will analyse retrofits and upgrades as well as new installations. It gives an invaluable insight into savings over the equipment's planned life.

EFFECTIVE CONTROL

HOWDEN WATER TECHNOLOGIES STRENGTH LIES IN OUR COMPREHENSIVE UNDERSTANDING OF THE APPLICATION. WE BRING TOGETHER EXPERTISE IN BLOWER TECHNOLOGY, DISTRIBUTED CONTROL TECHNOLOGY AND THE DOWNSTREAM AERATION PROCESS FOR WASTE WATER TREATMENT TO OFFER OUR CLIENTS THE VERY BEST TECHNICAL SUPPORT.

Today, single stage geared turbo blowers are the most efficient way to aerate treatment plants. The technology has been brought to an extremely advanced level, and the focus is now on highly efficient controls and downstream solutions that will make the overall air supply system of even higher value to the end user. The aim is to constantly offer the client the optimum solution and the lowest cost of ownership.

To ensure that the aeration system is always making the most effective and appropriate use of all the blowers, and thus running as efficiently as possible, Howden Water Technologies offers a reliable load sharing system called Airflow Integrated Management (AIM). Incorporated into the Local Control Panels, the system provides several advantages.

- By integrating master and local control in one panel, it removes the need for a separate Master Control Panel and so removes the potential for faults arising in a separate Programmable Logic Controller.
- It maximises energy savings through the use of the Most Open Valve principle, an approach designed to prevent the blowers wasting energy by creating more pressure drop in the control valves than the plant needs at the time.
- It reduces the need for starting and stopping of the blowers, and reduces down time.
- The integral Air Blower Duty Hour Equalising feature ensures that duty hours are shared evenly across all blowers.



HOWDEN'S *BIOACTIVE RESPONSE SYSTEM (BARS)*

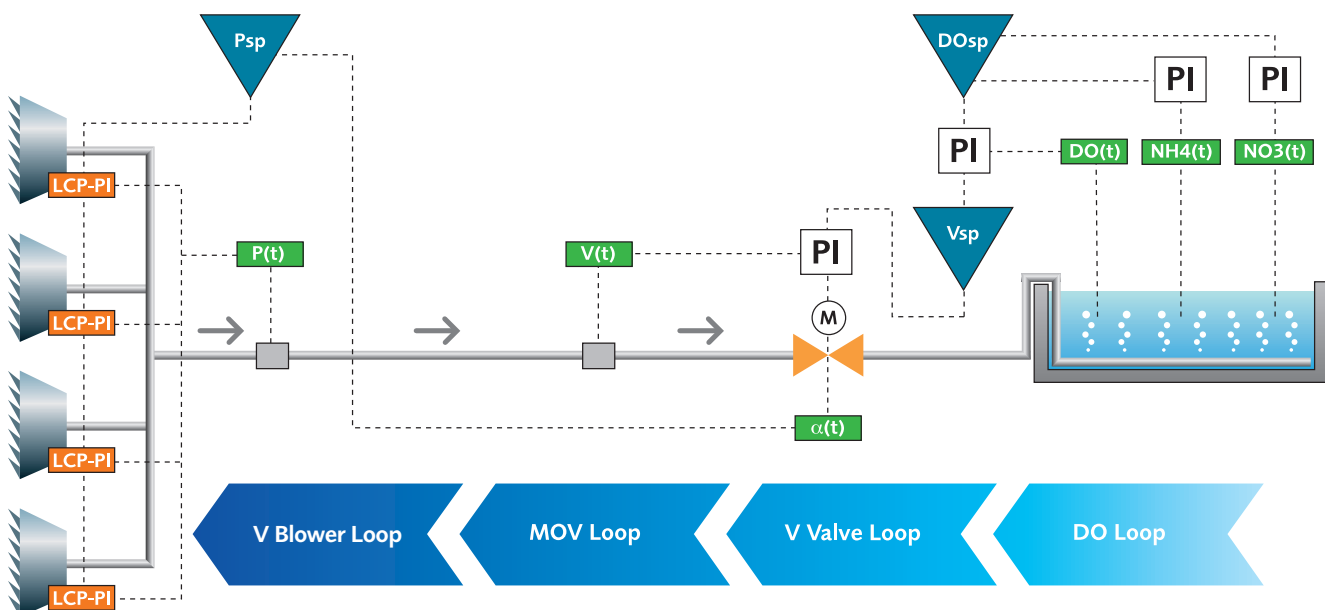



Howden Water Technologies BioActive Response System combines the energy efficient AIM system with a downstream air distribution system in which four control loops interact in real time to produce the minimum air flow required to efficiently treat the water in the Aeration Tanks. By constantly maintaining the lowest possible Main Header air pressure, BARS prevents unnecessary energy consumption and reduces running costs.

The first control loop sets the dissolved oxygen level set-point based on readings of the ammonium and nitrate levels in the water. The second loop uses the dissolved oxygen level deviation from the DOL set-point as basis for setting the air flow set-point of the air control valves. The third loop sets the main header pressure set-point based on readings of the most open control valve position and finally the fourth loop controls the air flow discharged from the on-line blowers keeping a constant main header pressure.

Howden Water Technologies can provide all the necessary hardware and software, and supply the complete control system. As well as maximising efficient running and thus lowers energy costs, this gives the customer the advantage of dealing with a single supplier.

BARS also allows plant operators to build in a range of special programme features to respond automatically when normal plant operating conditions are breached. Dedicated programmes can also be built in for procedures like normal start-up, tank cleaning and backwash filter cleaning, and special routines can be included to handle situations such as start-ups where there may be water in the pipes (leading to danger of surge) or storm water influx where high air throughput is required for a short time.

LIFETIME CUSTOMER CARE

EVERY TURBO BLOWER WE SUPPLY, AND ALL OF ITS ASSOCIATED CONTROL AND SOFTWARE SYSTEMS, IS BACKED BY AN UNEQUIVOCAL COMMITMENT TO LIFETIME SUPPORT. HOWDEN'S GLOBAL NETWORK OF QUALIFIED SPECIALIST ENGINEERS MEANS THAT WE CAN OFFER A FAST LOCAL RESPONSE VIRTUALLY ANYWHERE IN THE WORLD WHEN REQUIRED.

We maintain a full spares programme based on meticulous documentation of the equipment we originally installed, so that every part we supply is manufactured to specification. More importantly, our records are a valuable resource that allows us to provide reliable advice rapidly when plant conditions may change or other factors such as

technological developments may make retrofits or upgrades advisable.

RAPID RESPONSE

We are happy to discuss any aspect of water aeration technology, from consultation as systems provider at the planning stage to advising on possible retrofits

and modernisation of existing plant irrespective of age, location or original supplier. Our modelling software can provide a wealth of hard information to assist decisions about the timing and scope of plant modernisation. And because we are focused solely on the needs of the industry we operate 24/7 for our clients.



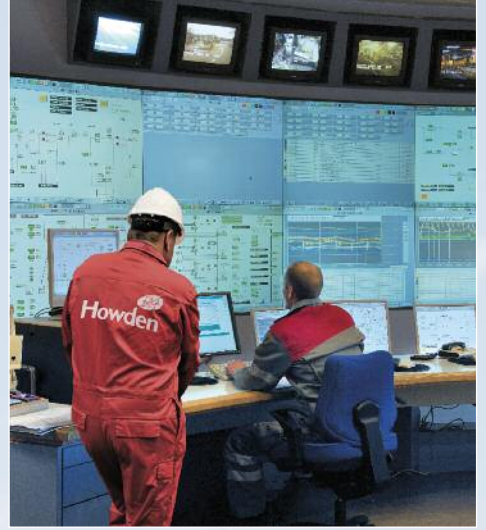

MANUFACTURING, SALES AND REGIONAL SPARES, REPAIRS AND SERVICE CENTRES FOR HOWDEN COMPRESSOR PRODUCTS THROUGHOUT THE WORLD

Regional Compressor Sales and Service Centres

Compressor Manufacturing Centres of Excellence

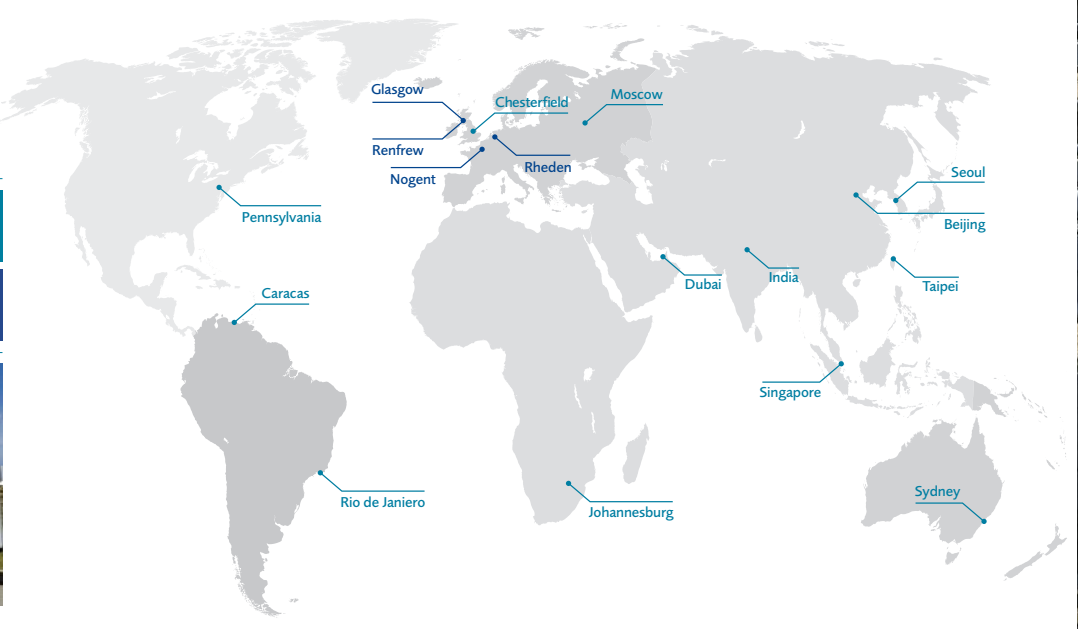

PASSION FOR COMPRESSION

Howden, founded in 1854, is a world leading supplier of compressors, fans and rotary regenerative heat exchangers for a large range of industrial applications. Whether pre-engineered or custom built for a specific application, our products are known throughout the world for their high levels of performance, reliability and innovation.

The combination of our product knowledge with our extensive applications experience, gained by our engineers on sites throughout the world, allows us to provide our customers with full support, from the initial project inception right through to the end of the plant life.

Howden Compressor Division companies occupy a unique position in compressor design and manufacturing. We pioneered many of the technologies that the global oil and gas, petrochemical, industrial refrigeration, power and chemical industries now rely on.

Related publications:

The following publications are available upon request or by download from our website www.howden.com/compressors



Howden Compressor Division



Turbo Blowers & Compressors

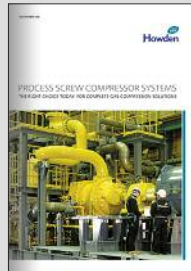

Process Gas Compressor Systems

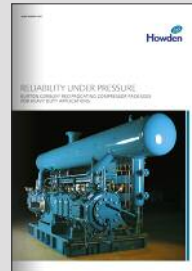

Howden Burton Corblin

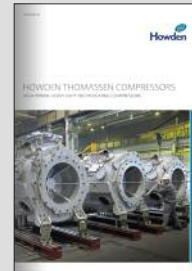

Howden Thomassen Compressors



Howden Compressors



HOWDEN WATER TECHNOLOGIES PART OF HOWDEN PROCESS COMPRESSORS

Head Office
Old Govan Road, Renfrew PA4 8XJ
United Kingdom

Sales & Service Centre
Park Road, Holmewood Industrial Park
Chesterfield S42 5UY
United Kingdom

Turbo Blower Sales
Tel: +44 1246 859 053
Email: blowers.sales@howden.com

Spare Parts & Service
Tel: +44 1246 859 053
Email: blowers.aftersales@howden.com

